



**RANGO DE MODELOS
DESDE 1 A 3 M³**

**RANGE OF MODELS
FROM 1 TO 3 M³**

- MES1500
- MES2250
- MES3000
- MES3750
- MES4500
- MES1500 BP
- MES2250 BP
- MES3000 BP
- MES3750 BP
- MES4500 BP



- Máquinas de Alto Rendimiento diseñadas para el sector:
 - Hormigón / Prefabricado
 - Mezclas especiales
- Mezcladora pensada para plantas de hormigón dosificadoras con doble vía, seca y amasadora
- Cuba de construcción sólida.
- Forros anti-desgaste, en chapa de acero, ofreciendo 400HB, con 10mm de espesor.
- Hélice de mezcladora con forros en fundición 610 HB con 20mm de espesor.
- Compuerta de descarga de accionamiento hidráulico provista de forros de desgaste.
Versión MES BP con compuerta de carga lateral vía By-pass, entrada de producto a mezcladora o carga a salida directa.



- High performance mixers specifically designed for the sectors:
 - Readymix Concrete / Precast
 - Special mix
- Mixer designed for dosifier concrete plants with double track, dry and blend
- Solid construction cask.
- 10 mm alloy steel lining, 400 HB, for a minimum wearness.
- Mixer helix with smelting covers 610 HB, 20mm thick. Hydraulic lockgate provided with scuffing covers. MES BP version with lateral loading lockgate via By-pass, product entry into mixer or direct output load.



MODELOS / MODELS		1500	1500BP	2250	2250BP	3000	3000BP	3750	3750BP	4500	4500BP
CAPACIDAD / DRY BATCH CAPACITY	Lt	1500	1500	2250	2250	3000	3000	3750	3750	4500	4500
HORMIGÓN POR CICLO / OUTPUT PER BATCH	M ³	1	1	1,5	1,5	2	2	2,5	2,5	3	3
FUERZA MOTRIZ / DRIVE POWER	Kw	37	37	55	55	75	75	100	100	110	110
BRAZOS MEZCLA / MIXING ARMS	Nº	4									
PESO DE MEZCLADORA / MIXER WEIGHT	Kg	4.400	4.800	5.400	5.800	6.100	7.500	8.700	9.200	10.600	11.300
COMPUERTA BY-PASS CARGA / BY-PASS LOCKGATE	Nº	0	1	0	1	0	1	0	1	0	1
BRAZOS RASCADORES / SCRAPERS ARMS	Nº	2									
POTENCIA HIDRAULICO / HYDRAULIC POWER	KW	3									
GRANULOMETRIA / AGGREGATS SIZE	mm	De 0 a 100 32 - 60 - 30% max 60 - 80 - 10% max 80 - 100 - 10% max									

MODELOS / MODELS	MEDIDAS / MEASURES mm					
	A	B	C	D	E	F
MES1500	1600	1980	1300	1600	1500	2900
MES1500BP	1600	2600	1300	1600	1500	2900
MES2500	1600	1980	1300	1600	1800	3200
MES2500BP	1600	2600	1300	1600	1800	3200
MES3000	1600	1980	1300	1600	2200	3600
MES3000BP	1600	2600	1300	1600	2200	3600
MES3750	1870	2030	1610	1830	2030	3560
MES3750BP	1870	2730	1610	1830	2030	3560
MES4500	1870	2030	1610	1830	2030	3560
MES4500BP	1870	2730	1610	1830	2030	3560

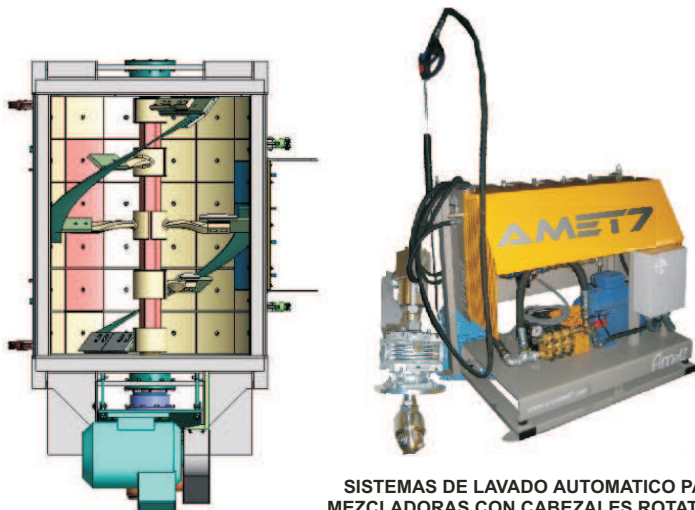
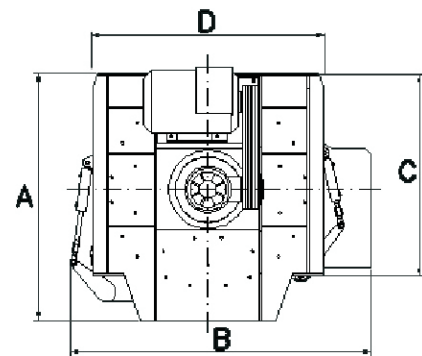
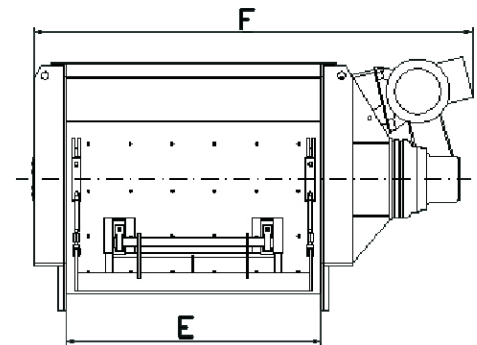

SISTEMAS DE LAVADO AUTOMÁTICO PARA MEZCLADORAS CON CABEZALES ROTATIVOS
HIGH-PRESSURE CLEANING SYSTEM FOR MIXERS WITH ROTATING WATER SPRAY NOZZLES

COMPLEMENTOS

- SISTEMA DE LAVADO AUTOMÁTICO
- SISTEMA ENGRASADO AUTOMÁTICO
- SISTEMA DOBLE COMPUERTA



COMPLEMENTS

- HIGH-PRESSURE CLEANING SYSTEM FOR MIXERS
- CENTRALIZED LUBRICATION AUTOMATIC SYSTEM
- SYSTEM DOUBLE GATE

www.arcomet7.com

ARCOMET7 S.L.

Pol. Ind. Centrovía, C/ Buenos Aires, Nº12 - Nave A
50198 La Muela, Zaragoza (España)

TELF: +34 976 141873 FAX: +34 976 144763

www.arcomet7.com

arcomet7@arcomet7.com

DELEGACIÓN
ZONA CATALUÑA
Tel. +34 619 70 36 20

DELEGACIÓN
ZONA CENTRO
Tel. +34 680 980 628

DELEGACIÓN
ZONA NORTE
Tel. +34 636 964 104

ARLACO LDA.
Tel. +35.1227128279
www.arlaco.pt