

**RANGO DE MODELOS DESDE
0,25 A 3 METROS CUBICOS**
**RANGE OF MODELS FROM
0,25 TO 3 M³ OUTPUT**

- ❑ MST375
- ❑ MST500
- ❑ MST750
- ❑ MST1125
- ❑ MST1500
- ❑ MST2250
- ❑ MST3000
- ❑ MST3750
- ❑ MST4500



- ❑ Máquinas de Alto Rendimiento diseñadas para el sector de:
 - Prefabricado
 - Hormigón
 - Morteros
 - Mezclas Especiales
 - Terrazos
- ❑ Dimensionado motor / reductor para 37 / 45 Kw por cada m³
- ❑ Forros interiores de 10 mm de aleación de acero, con 400 HB, para un desgaste mínimo.
- ❑ Compuertas de descarga hidráulicas / neumáticas según modelos (ver tabla adjunta).
- ❑ Palas de mezcla en goma con factor antidesgaste de 65 shores o en fundición antidesgaste, para una mayor durabilidad.



- ❑ High performance mixers specifically designed for the sectors:
 - Readymix Concrete
 - Wet cast / Precast
 - Mortar
 - Special Mix
 - Terrazzo
- ❑ Dimensioned reductor / motor for 37 / 45 Kw for each m³.
- ❑ 10 mm alloy steel lining, 400 HB, for a minimum weariness.
- ❑ Hydraulic / pneumatic unload lockgates according to models (see tabala attached)
- ❑ Mixing Paddles in Goma with wear and tear factor of 65 shores or in casting anti-wear, for greater durability.

MODELOS / MODELS		375	500	750	1125	1500	2250	3000	3750	4500
CAPACIDAD / DRY BATCH CAPACITY	Lt	375	500	750	1125	1500	2250	3000	3750	3750
HORMIGÓN POR CICLO / OUTPUT PER BATCH	M ³	0,25	0,33	0,5	0,75	1	1,5	2	2,5	3
FUERZA MOTRIZ / DRIVE POWER	Kw	15	15	22	30	37	55	75	90	110
POTENCIA HIDRAULICO / HIDRAULIC POWER	Kw	2,2	2,2	2,2	2,2	2,2	2,2	2,2	2,2	2,2
BRAZOS MEZCLA / MIXING ARMS	Nº	1	1	1	1	1	2	2	3	3
PESO DE MEZCLADORA / MIXER WEIGHT	Kg	1200	1800	2450	3500	4100	5240	5865	11300	11500
ACCIONAMIENTO COMPUERTAS/ GATES DRIVE	Pneumatic	X	X							
	Hydraulic			X	X	X	X	X	X	X
PUNTOS INYECCION AGUA/ WATER DISTRIBUTION POINTS	Nº	12	12	12	12	12	15	15	20	20
GRANULOMETRIA / AGGREGATS SIZE	Mm	0-28	0-28	0-36	0-36	0-40	0-40	0-40	0-40	0-40

COMPLEMENTOS OPCIONALES / OPTIONALS COMPLEMENTS



SISTEMA DE LAVADO AUTOMÁTICO CICLO A CICLO
MEDIANTE CABEZALES ROTATIVOS



AUTOMATIC FLUSHING SYSTEM CYCLE TO CYCLE
THROUGH ROTARY HEADS

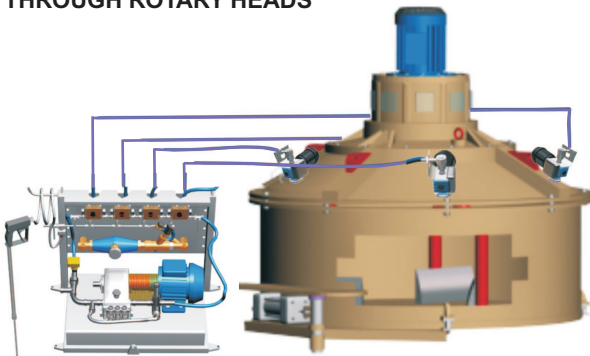

COMPUERTAS DE DESCARGA ADICIONALES
HASTA 3 COMPUERTAS SEGÚN MODELOS



DISCHARGE GATES MAY BE EQUIPPED WITH
UP TO 3 SOME MODELS

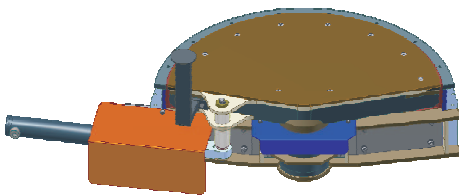

MODELOS / MODELS

MEDIDAS / MEASURES mm

	A	B	C	D	E	F
MST375	1400	1560	675	475	1912	1636
MST500	1640	1760	575	475	1812	1876
MST750	1846	1946	815	515	2154	2123
MST1125	2200	2260	840	500	2228	2332
MST1500	2200	2260	940	500	2328	2332
MST2250	2700	2810	950	515	2673	3130
MST3000	2700	2810	1100	515	2823	3130
MST3750	3270	3410	1255	525	3400	3500
MST4500	3270	3410	1255	525	3500	3500

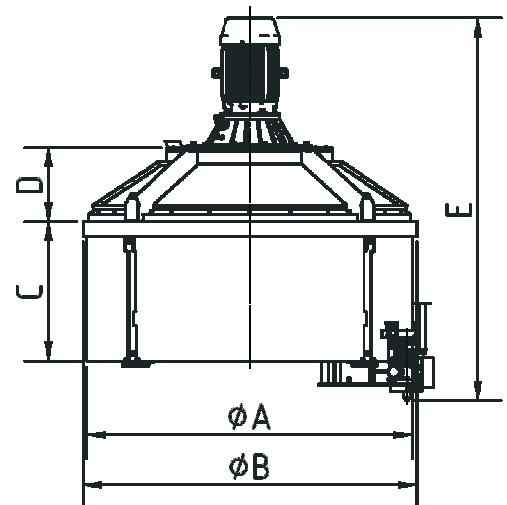
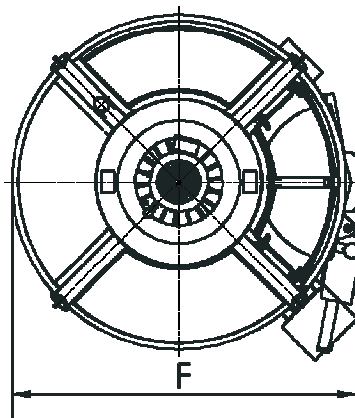

www.arcomet7.com

ARCOMET7 S.L.

Pol. Ind. Centrovía, C/ Buenos Aires, Nº12 - Nave A
50198 La Muela, Zaragoza (España)

TELF: +34 976 141873 FAX: +34 976 144763

www.arcomet7.com

arcomet7@arcomet7.com

DELEGACIÓN
ZONA CATALUÑA
Tel. +34 619 70 36 20

DELEGACIÓN
ZONA CENTRO
Tel. +34 680 980 628

DELEGACIÓN
ZONA NORTE
Tel. +34 636 964 104

ARLACO LDA.
Tel. +35.1227128279
www.arlaco.pt