



- RANGO DE MODELOS DESDE
0,5 A 3,5 METROS CÚBICOS**
- RANGE OF MODELS FROM
0,5 TO 3,5 M³ OUTPUT**
- ❑ MV750
 - ❑ MV1125
 - ❑ MV1500
 - ❑ MV2250
 - ❑ MV3000
 - ❑ MV4500
 - ❑ MV5250



- ❑ Máquinas de Alto Rendimiento diseñadas para el sector de:
 - Hormigón / Prefabricado
 - Refractario
 - Vidrio
 - Inertizado / Medio ambiente
- ❑ Dimensionado motor / reductor para 37 Kw por cada m³.
- ❑ Forros interiores de 10mm en aleación de acero con 400HB para una mayor duración.
- ❑ Palas de fundición Ni_Hard superior, para mínimo desgaste.
- ❑ Compuertas de descarga hidráulicas.



- ❑ High performance mixers specifically designed for the sectors:
 - Readymix Concrete / Precast
 - Refractory / Heat-resistant
 - Glass industry
 - Inerted / Environment
- ❑ Dimensioned reductor / motor for 37 Kw for each m³.
- ❑ 10 mm alloy steel lining, 400 HB for a longer duration
- ❑ With a high Ni_Hard, quality for minimum weariness
- ❑ Discharge gates hydraulically operated.

MODELOS / MODELS		750	1125	1500	2250	3000	4500	5250
CAPACIDAD / DRY BATCH CAPACITY	Lt	750	1125	1500	2250	3000	4500	5250
HORMIGÓN POR CICLO / OUTPUT PER BATCH	M ³	0,5	0,75	1	1,5	2	3	3,5
FUERZA MOTRIZ / DRIVE POWER	Kw	22	30	37	55	75	110	132
BRAZOS MEZCLA / MIXING ARMS	Nº	5	6	6	8	10	13	15
PESO DE MEZCLADORA / MIXER WEIGHT	Kg	2500	3500	4600	7300	9000	11400	12500
ACCIONAMIENTO COMPUERTAS / DISCHARGE GATES DRIVE		MANUAL		MANUAL + HIDRÁULICO / MANUAL + HYDRAULIC			2,2 KW	
BRAZOS RASCADORES / SCRAPERS ARMS			All models: 2		GRANULOMETRIA / AGGREGATS SIZE			0,08-80 mm

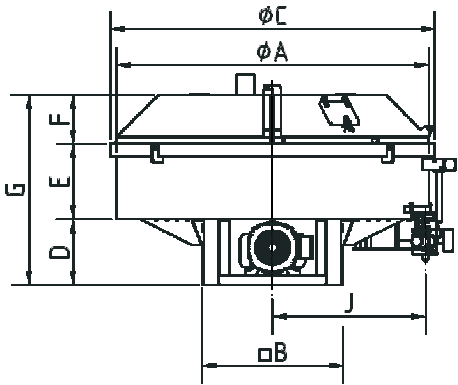

MODELOS / MODELS	MEDIDAS / MEASURES mm									
	A	B	C	D	E	F	G	H	J	
MV750/1125A	2200	1000	2300	400	710	350	1460	2230	1100	
MV750	2110	1000	2210	450	500	315	1265	2210	1000	
MV1125	2410	1100	2520	505	545	450	1500	2520	1175	
MV1500	2410	1100	2520	505	645	450	1600	2520	1175	
MV2250	2882	1300	2992	605	695	450	1750	3163	1410	
MV3000	3250	1500	3370	650	650	500	1800	3441	1575	
MV4500	3720	1600	3840	755	845	500	2100	4070	1800	
MV5250	4130	1800	4250	800	800	555	2155	4250	2030	

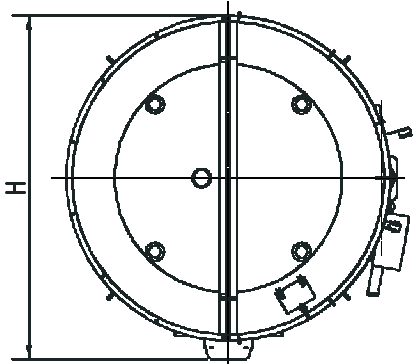

COMPLEMENTOS OPCIONALES / OPTIONALS COMPLEMENTS



SISTEMA DE LAVADO AUTOMÁTICO CICLO A CICLO MEDIANTE CABEZALES ROTATIVOS



AUTOMATIC FLUSHING SYSTEM CYCLE TO CYCLE THROUGH ROTARY HEADS



COMPUERTAS DE DESCARGA ADICIONALES HASTA 3 COMPUERTAS SEGÚN MODELOS



DISCHARGE GATES MAY BE EQUIPPED WITH UP TO 3 SOME MODELS

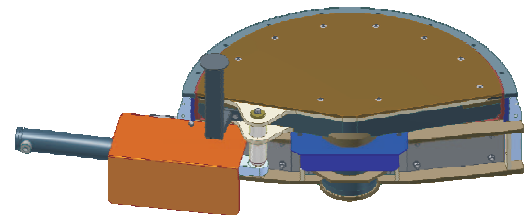
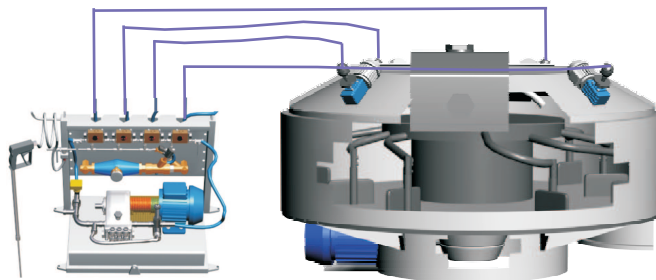

www.arcomet7.com

ARCOMET7 S.L.

Pol. Ind. Centrovía, C/ Buenos Aires, Nº12 - Nave A
50198 La Muela, Zaragoza (España)

TELF: +34 976 141873 FAX: +34 976 144763

www.arcomet7.com

arcomet7@arcomet7.com

DELEGACIÓN
ZONA CATALUÑA
Tel. +34 619 70 36 20

DELEGACIÓN
ZONA CENTRO
Tel. +34 680 980 628

DELEGACIÓN
ZONA NORTE
Tel. +34 636 964 104

ARLACO LDA.
Tel. +35.1227128279
www.arlaco.pt